

Programmable Operator Interface















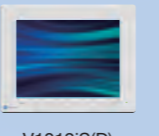



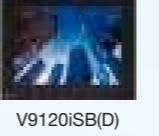
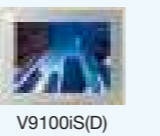

MONITOUCH

The new standard for high speed HMI

V10 STANDARD MODEL
Series

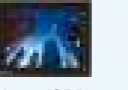

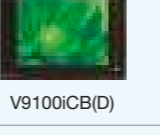
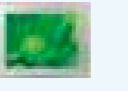
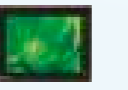
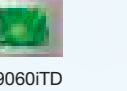
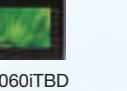
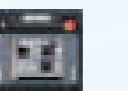
Meeting customer needs through a lineup of products with various specifications and sizes.

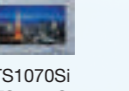
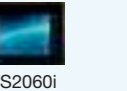
	15.6" wide	15.0"	12.1" wide	12.1"	10.4"	10.2" wide	10.1" wide	8.4"	7.5"	7.0" wide	5.7"
X1 Series Quad-core CPU Windows OS model	 X115iSD		 X112iSD								
V10 Series Quad-core CPU high performance model		Standard  V1015iS(D)  V1015iSB(D)		Standard  V1012iS(D)  V1012iSB(D)	Standard  V1010iS(D)  V1010iSB(D)			Standard  V1008iSD  V1008iSBD			
V9 Series High performance model		Standard  V9150iX(D)		Standard  V9120iS(D)  V9120iSB(D)	Standard  V9100iS(D)  V9100iSB(D)		Advanced  V910iWD	Standard  V9080iSD  V9080iSBD		Advanced  V907iWD	
					Lite  V9100iC(D)  V9100iCB(D)			Lite  V9080iCD  V9080iCBD			Lite  V9060iTD  V9060iTBD
V8 Series Handy model									 V808(i)CH		
TS1000S Series Basic model						 TS1100Si				 TS1070Si TS1070S	
TS2000 Series Basic model											 TS2060i TS2060

MONITOUCH



Realizing smooth,
stress-free operation
with functions required for HMI



The chief reason to select the V10 series is its overwhelming performance against competitors.

Industry best performance^{*1}



In addition to benchmarking HMIs from all over the world, we thoroughly analyzed how they were used in the field, and achieved industry-leading performance in six aspects (rendering, operation, startup, communication, transfer and custom code).

-  **Rendering**
Highest screen switching speed
-  **Operation**
Quickest input response time

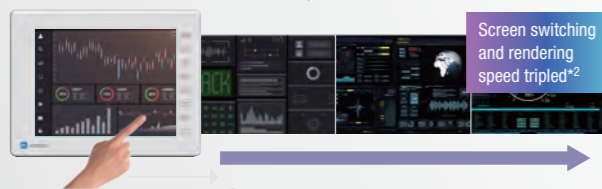
Reducing the stress of switching screens



Smooth screen switching and continuous operation

-  **Start-up**
Shortest startup time from power-on
-  **Transferring**
Highest screen data transfer speed!!

Reducing the stress of wait time

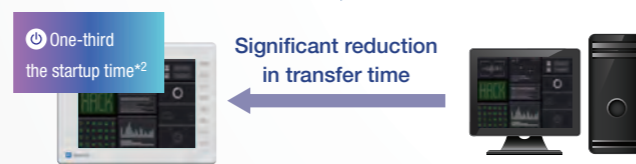

Reducing the wait time for startup and screen transfer

-  **Communication**
Highest communication speed

Reducing the reading and writing time of multipoint data

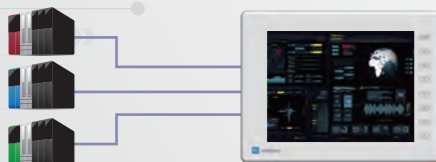

Smooth operation even with multiple devices connected for multi-point logging

-  **Custom Code**
Highest processing speed for macro command execution!

Reducing stress in the operation of high-load screens



Stable operation even for four arithmetic operations and logical operation in multiple lines, comparison and transfer

- XGA SVGA
- 16.7M Colors
- Serial 3ch
- LAN 1ch
- SD I/F
- USB A/mini B
- Audio
- COM I/F Option
- VIDEO Option
- RGB Option

Minimal development cost in HMI replacement!



*1 Comparison with currently available products of the world's major HMI manufacturers using our sample screen programs (according to our own research)

*2 Comparison with V9 series using our sample screen programs (according to our own research)

*3: Expansion units (Video/RGB) for the V10 series are under development, scheduled to be released in April 2024.



V10 Standard



Advantages to use the V10 series

Operation / Communication

High-speed processing of quad-core CPU allows for stable operation and communication performance even on high-load screens!

Start-up / Transfer

Advanced storage device (eMMC) reduced startup/transfer time and man-hours!

Compatibility

Fully compatible in panel cutout sizes and functions with existing V series!



Benefits for every department!

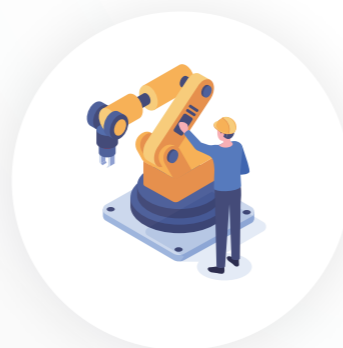
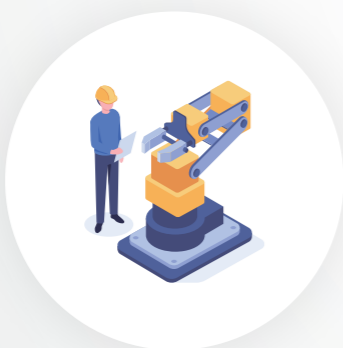

Designer

Start-up / Transfer

Reduced wait time for start-up and screen data transfer!

Compatibility

Reduced debugging time for system updates thanks to full compatibilities with previous models!

Operator

Start-up / Transfer

Reduced start-up wait time!

Operation / Communication

Smooth setup and operation is now possible!

Maintenance Engineer

Compatibility

Identical panel cutout size allows for easy updating from existing models.

Operation / Communication

Smooth screen switching enables quick location of the error source when troubleshooting.

Model	V1015iS	V1012iS	V1010iS	V1008iS
Display size	15.0"	12.1"	10.4"	8.4"
Display device	TFT color LCD	TFT color LCD	TFT color LCD	TFT color LCD
Resolution	1024x768	800x600	800x600	800x600
Colors	16.7 million*1	16.7 million*1	16.7 million*1	16.7 million*1
Touch switch	Analog resistance film	Analog resistance film	Analog resistance film	Analog resistance film
Screen memory (FROM)	256MB	256MB	256MB	256MB
Backup memory (SRAM)	900KB	900KB	900KB	900KB
Ethernet (LAN)	✓	✓	✓	✓
Extended cable LAN	△*2	△*2	△*2	△*2
Wireless LAN	△*2	△*2	△*2	△*2
Serial (D-Sub9 pin: CN1)	RS-232C/422/485	RS-232C/422/485	RS-232C/422/485	RS-232C/422/485
Serial (Modular 8 pin: MJ1/MJ2)	RS-232C/485	RS-232C/485	RS-232C/485	RS-232C/485
Communication I/F (CUR-XX)	✓	✓	✓	✓
Optional unit I/F (GUX-XX)*3	△*3	△*3	△*3	△*3
SD card	✓	✓	✓	✓
USB (Type A)	✓	✓	✓	✓
USB (Type mini-B)	✓	✓	✓	✓
Sound output	✓	✓	✓	✓

*1 Picture, 3D part, video and RGB input (excluding high speed mode) only. Other parts are displayed in 65,536 colors. *2 Differs depending on the model. *3 Under development. Scheduled to be released in April 2024.

Security Features

The V10 series simplifies complex security management.

Before

PCs were introduced for security control, however...

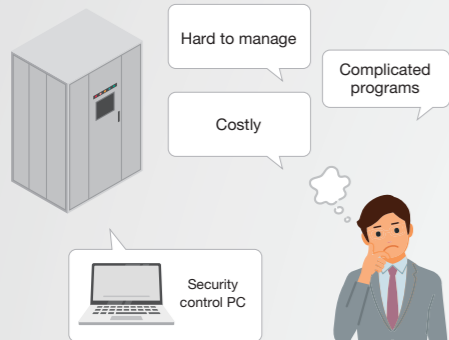

After

Display and operation permission can be controlled for each operator by setting the security level. User IDs and passwords can be registered, changed or deleted on the V10 easily.

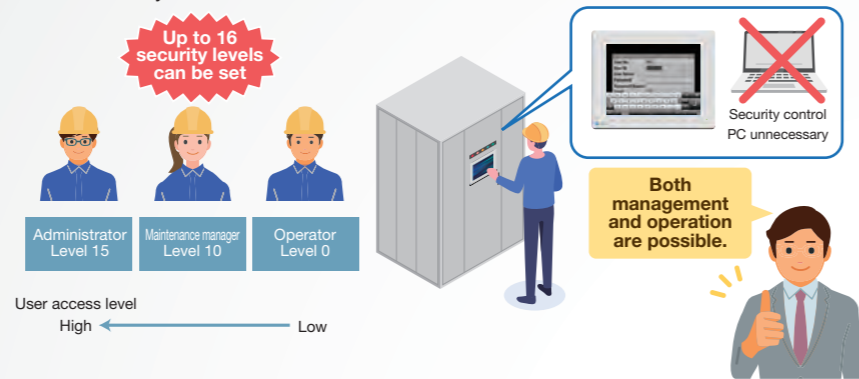

Operation Log Function

Realizing traceability leads to speedy identification, analysis and resolution of problems.

Before

When an alarm occurs, I can't see the history leading up to it and I don't know the cause. I want to achieve traceability, but I don't know what to do...



After

Operators' activity and machine settings can be confirmed. Quick identification of the cause and early resolution of problems are possible, contributing to the improvement of yield rate and a decrease of defective products.

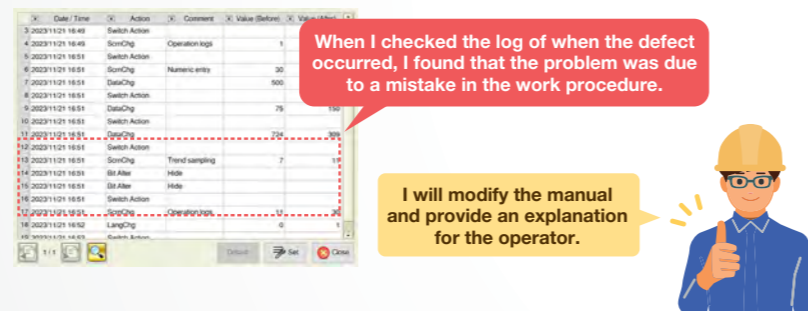

Reporting Function

Paperless operation contributes to carbon neutrality.

Before

Currently we output inspection results via hardcopy printing, however we want to set up a paperless system...



After

In the V10 series, data can be displayed in an easy-to-read format using graphs and meters, and PDF output is possible. It is also possible to output the data with an electronic handwritten signature.

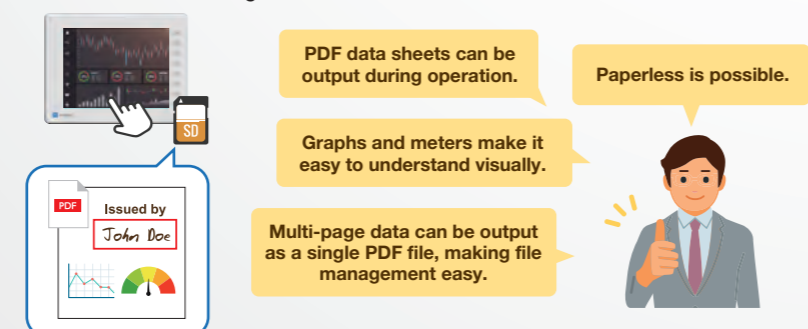

Event Recording Function

Problem identification is possible via monitoring and recording using an off-the-shelf USB camera.

Operation status before and after the error can be recorded. By looking back at the saved video, causes can be identified quickly and easily, improving on-site operating efficiency.

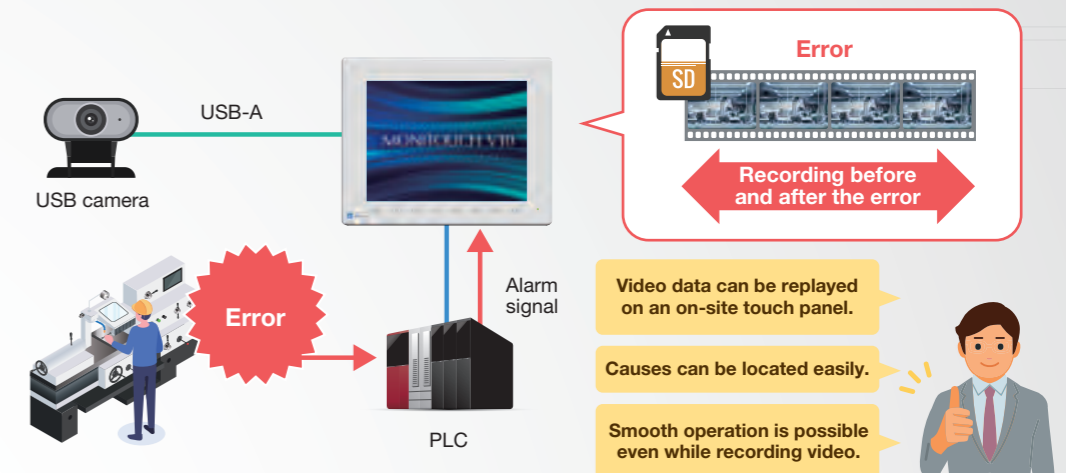

Network Cameras

Camera feeds ensure safety and improve operation efficiency.

Camera feeds displayed on the V10 series enable you to grasp the status of the entire system, leading to safety improvement and decreased accidents. Viewing camera feeds is helpful when adjusting and checking the moving parts in large systems. Confirmation time and the number of operators can be reduced.

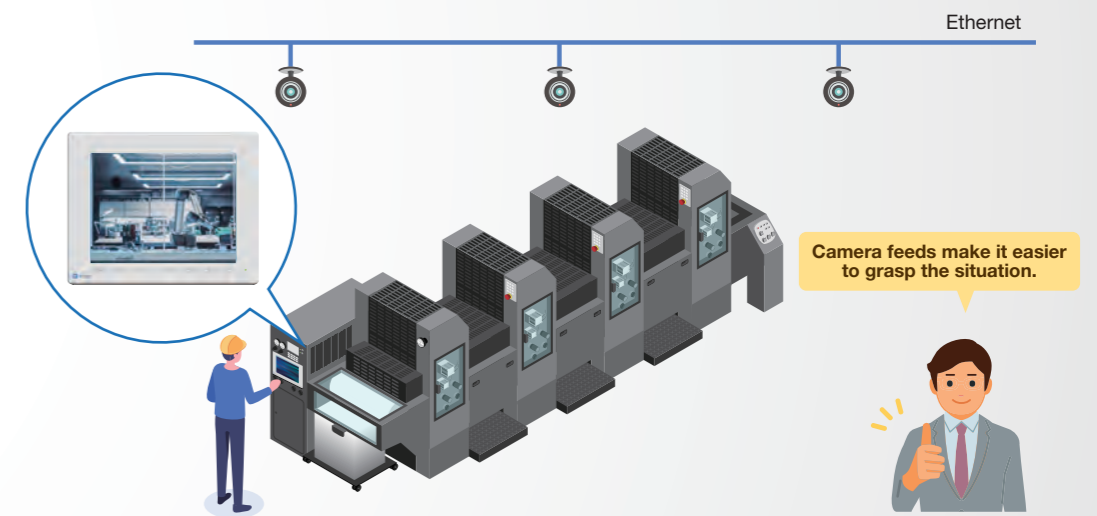

Video Replay

Operators can check the video manual on-site, improving understanding of operation procedures.

Video files can be played on the V10 series. Since operation procedures can be checked by viewing videos, operators can respond to errors and conduct maintenance work without depending on experienced workers. Quick response and restoration is possible.



8-way Communication

Reduce program design time and connection unit equipment costs.

Reduce the time required to design programs by having the V10 series handle the connection with devices. Equipment can be expanded without the need for units, leading to cost reduction. Additionally, data can be shared between devices at intervals specified by the V10 series.

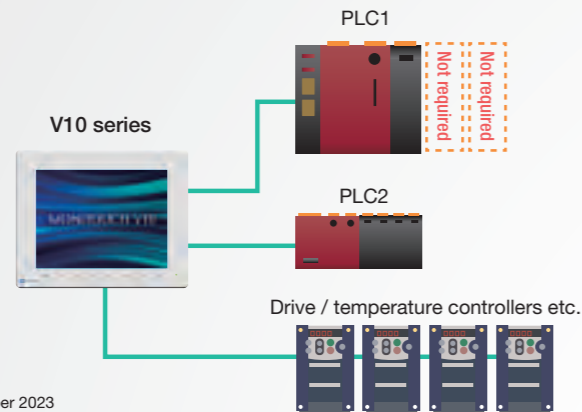

*1 According to our research *2 As of November 2023

Industry-leading number of connectable devices*1

77 manufacturers 459 protocols*2

Connectable device list
<https://monitouch.fujielectric.com/site/support-e/list27.html>

VNC Server Function

Reduce debugging and maintenance time through remote monitoring and operation.

The V10 series screen can be viewed and operated via a tablet*3 or computer. When debugging or making adjustments, you can operate and check the V10 without being in front of it, saving significant time. Our "Simple Remote" VNC application is available free of charge, so you can rest assured regarding support.



*3 A wireless router is required for models other than wireless LAN compatible models.

Trend Analysis

Compare and display past and current trends. Understand changes in data and use it for preventive maintenance.

Before

I'm checking the quality of products using trend graphs, but there is nothing to compare them to, so it is difficult to understand whether the quality is good or bad...

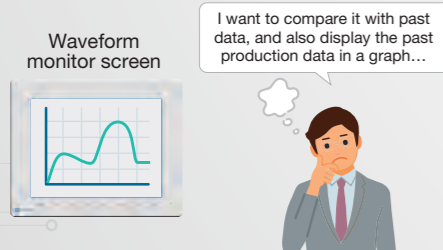

After

Past and current trend data can be superimposed. Visually understand trends in production data while checking changes in data during the manufacturing process in real time. Obtain improved yields by using it for preventive maintenance.

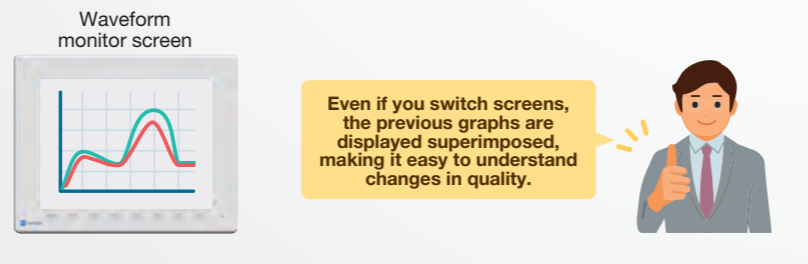

Scheduler Function

Prevent human error by scheduling function execution.

Operations can be scheduled and executed by month, day and time, preventing forgetting to execute due to human error. Since functions are executed automatically, it also leads to a reduction in work time.

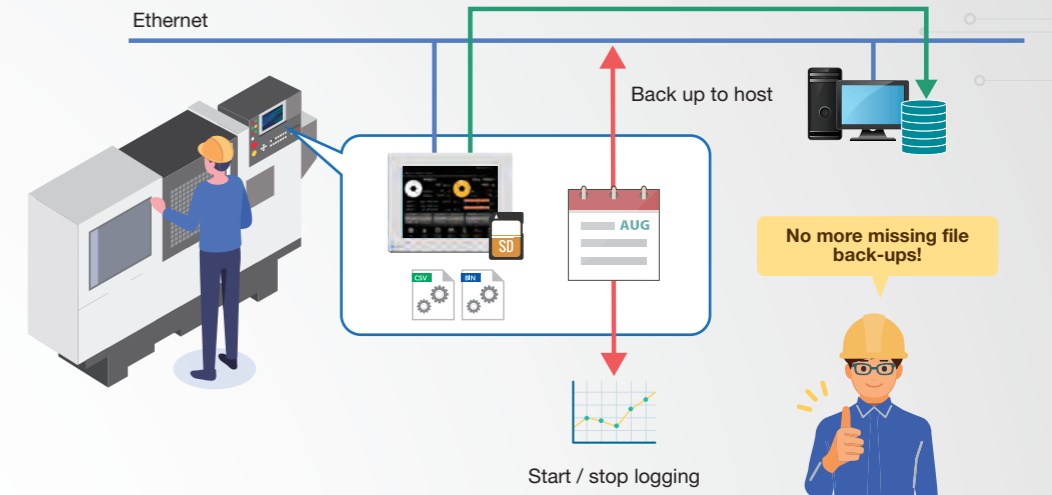

PDF Viewer

Immediately check manuals on-site, even in a clean room, which contributes to shortened recovery time.

Even in environments where you need to change your clothes or take an air shower, such as in a clean room, you can instantly check PDF files without going to the office to pick up the manual.

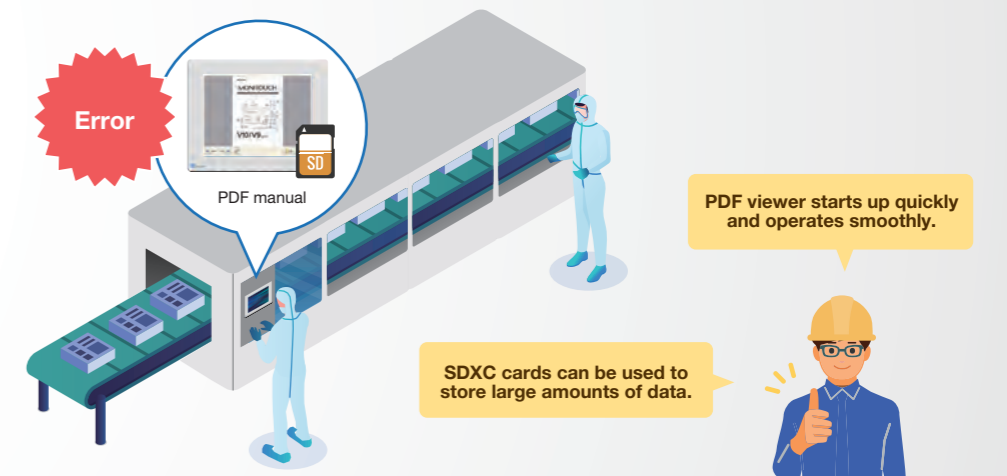

Scrolling

Understand the entire system with smooth scrolling, even when there is a large amount of information.

Before

Switching screens makes it difficult to understand the overall situation...



After

You can display an area up to 4x the display size; scroll to understand the overall situation even on screens that require a large amount of information, such as an overall plant diagram or error displays for each process.

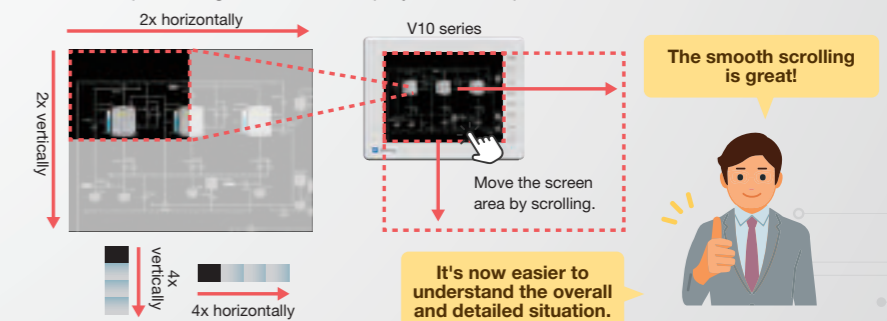

General Specifications

Item	V1015iS	V1015iSD	V1012iS	V1012iSD	V1010iS	V1010iSD	V1008iSD	
Power Supply	Rated Voltage	100~240V AC	24V DC	100~240V AC	24V DC	100~240V AC	24V DC	
	Permissible Range of Voltage	-15%, +10%	±10%	-15%, +10%	±10%	-15%, +10%	±10%	
	Permissible Momentary Power Failure	Within 20ms (100VAC or higher)	Within 1ms	Within 20ms (100VAC or higher)	Within 1ms	Within 20ms (100V AC or higher)	Within 1ms	
	Power Consumption (Max. Rating)	76VA or less	38W or less	53VA or less	25W or less	60VA or less	27W or less	25W or less
	Rush Current	56A or less, 3ms (Ambient temperature 25°C)	29A or less, 12ms (Ambient temperature 25°C)	48A or less, 3ms (Ambient temperature 25°C)	23A or less, 5ms (Ambient temperature 25°C)	43A or less, 3ms (Ambient temperature 25°C)	25A or less, 5ms (Ambient temperature 25°C)	21A or less, 6ms (Ambient temperature 25°C)
Insulation Resistance		Between AC external terminal and FG: 500V DC, 10MΩ or more Between DC external terminal and FG: 500V DC, 10MΩ or more						
Physical Environment	Operating Ambient Temperature	0~40°C *1		0~50°C *1				
	Operating Ambient Humidity	85%RH or less (without dew condensation, max. wet-bulb temperature 39°C or lower)*1						
	Operating Altitude	2,000m or less						
	Operating Atmosphere	No exposure to corrosive gas or conductive dust						
	Storage Ambient Temperature	-10~50°C *1		-10~60°C *1				
	Storage Ambient Humidity	85%RH or less (without dew condensation, max. wet-bulb temperature 39°C or lower) *1						
Mechanical Operating Conditions	Resistance to Oscillation	JIS B 3502 (IEC61131-2) compliant Vibration frequency 5 to 9Hz, Half amplitude: 3.5mm, 9 to 150Hz, Constant acceleration: 9.8m/s ² (1G) X, Y, Z 3 directions 10 times each						
	Resistance to Shock	JIS B 3502 (IEC61131-2) compliant Peak acceleration: 147m/s ² (15G), X,Y,Z 3 directions, 3 times each (18 times in total)						
Electric Operating Conditions	Resistance to Noise	Noise voltage:1,500Vp-p, pulse width:1μs, pulse rise time: 1ns (by noise simulator)	Noise voltage:1,000Vp-p, pulse width:1μs, pulse rise time: 1ns (by noise simulator)	Noise voltage: 1,500Vp-p, pulse width: 1μs, pulse rise time: 1ns (by noise simulator)				
	Resistance to Static Discharge	IEC61000-4-2 compliant, Contact: 6kV, air: 8kV						
Installation Conditions	Grounding	Grounding resistance: Less than 100Ω, FG/SG separation						
	Structure	Protection structure: Front case: IP66, Type 4X/13 ² (when water-proof gasket is used), Rear case: IP20 Installation method: panel mounting						
	Cooling System	Natural air cooling						
	Dimensions W*H*D (mm)	382.8×312.8×79.2	327.8×261.0×53.4	303.8×231.0×53.8	235.0×180.0×48.7			
	Panel Cutout W*H (mm)	369.4(+0.5/-0)×299.4(+0.5/-0)	313.0(+0.5/-0)×246.2(+0.5/-0)	289.0(+0.5/-0)×216.2(+0.5/-0)	220.5(+0.5/-0)×165.5(+0.5/-0)			
Case	Weight (display only)	Approx. 3.7kg	Approx. 2.6kg	Approx. 2.1kg	Approx. 1.4kg			
	Color	Front case, Surface sheet: Light gray / Black (black model) Rear case: Light gray						
Case	Material	PBT+GF30 resin						

*1 Use at a wet-bulb temperature of 39°C or less because higher temperatures may cause failure. *2 DC products only.

Performance Specifications

Item	V10 Standard			
	V1015iS	V1012iS	V1010iS	V1008iS
Screen Memory (FROM)	256MB			
Backup Memory (SRAM)	900KB			
Display	Display Device			
	Resolution			
	Display Size			
	Display Colors			
	Backlight			
Touch Switch	Type			
	Quantity			
External Interface	D-Sub 9-pin (CN1)			
	Modular 8-pin (MJ1/MJ2)			
	Ethernet			
	Wireless LAN *6			
	SD Card			
Clock	USB			
	Sound Output			
	Backup Period			
Standard	Calendar Accuracy			
	CE-UKCA *7			
	UL-cUL *7			
	KC			
Radio Act *6 *7				
Classification Standard *7 *10 *11				

*3 For displaying pictures, 3D parts, video, and RGB input (excluding high-speed mode) only. Other parts are displayed in 65,536 colors. *4 Only for Siemens MPI. *5 2CH for extended wired LAN products. *6 Wireless LAN compatible products only. *7 DC products only. *8 Hardware Ver. b or later. *9 For models incompatible with UL121201, please contact us. *10 Excluding wireless LAN compatible products. *11 Please contact us for more information.

Interface

Connection with a wide range of industrial networks

Model	Compatible network
CUR-00	OPCN-1
CUR-01	T-Link
CUR-02	CC-Link (Ver.1.10, Ver.2.00)
CUR-03	Ethernet (UDP/IP)
CUR-04	PROFIBUS-DP
CUR-06	SX-bus
CUR-07	DeviceNet
CUR-08	FL-net (Ver.2.00)
CUR-09	EtherCAT

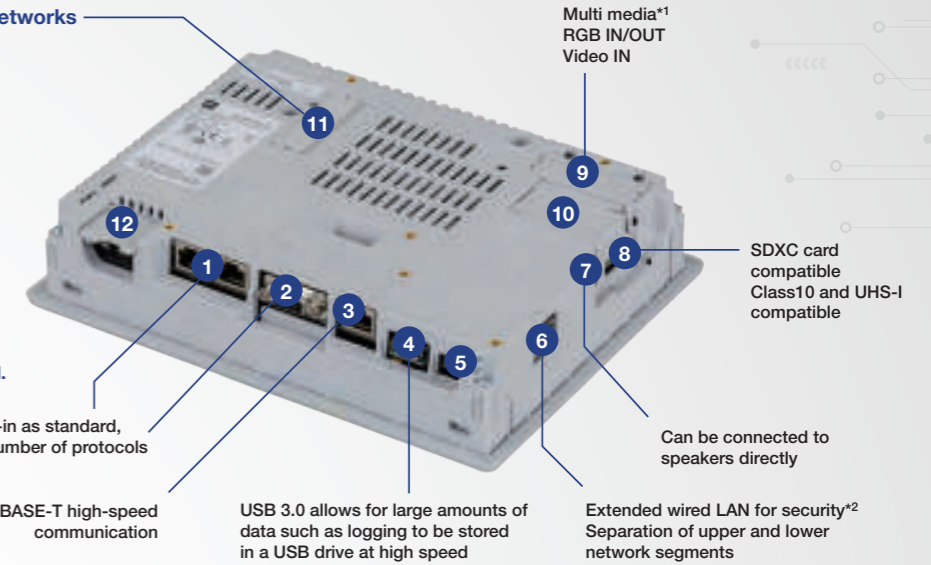

Communication units for the V9 series can be used.

- 1 Modular jack (RJ45) x 2
- 2 D-SUB 9 pin x 1
- 3 Wired LAN x 1
- 4 USB Type A Ver. 3.0 x 1
- 5 USB mini-B Ver. 2.0 x 1
- 6 Extended wired LAN*2 x 1
- 7 Audio jack x 1
- 8 SD Card x 1
- 9 Expansion Units*1
- 10 Battery V9-BT
- 11 Communication Units
- 12 Power supply terminal block

*1 Under development; scheduled for release in April 2024. *2 Extended wired LAN products only.

Dimensions

V1015iS

(Unit: mm)

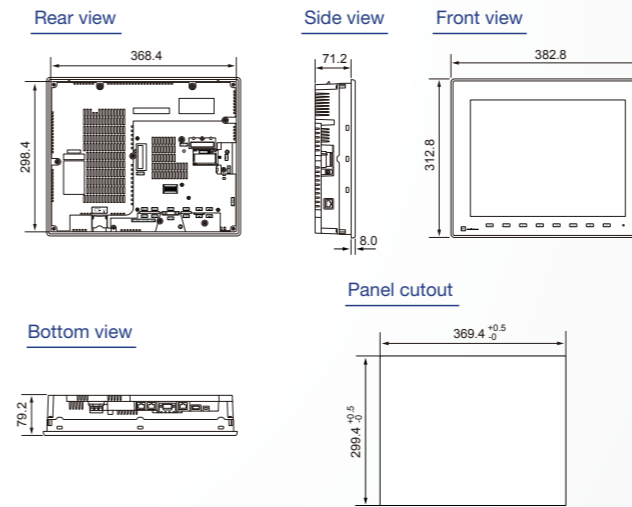

V1012iS

(Unit: mm)

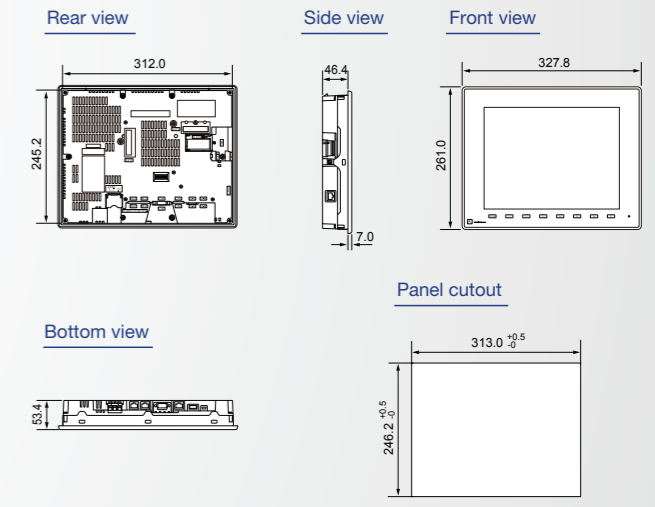

V1010iS

(Unit: mm)

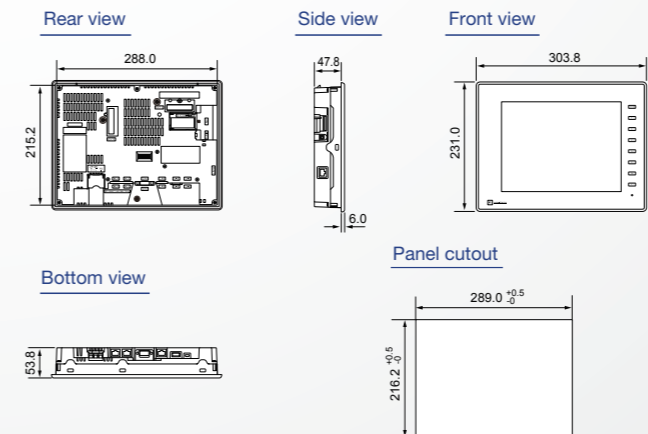

V1008iS

(Unit: mm)

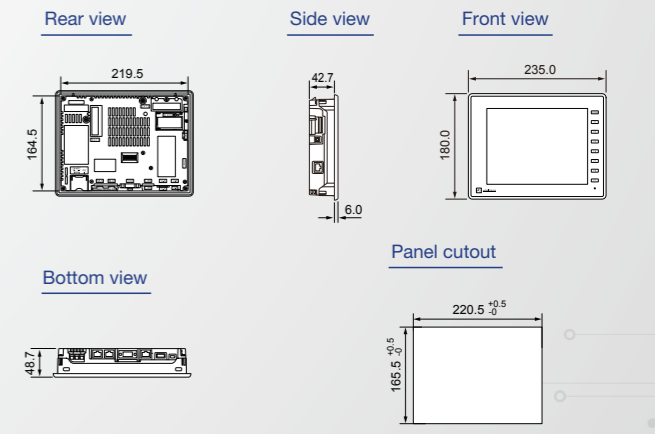

Achieve sleeker screens with simple, easy-to-understand operations

V-SFT Ver.6^{*1}

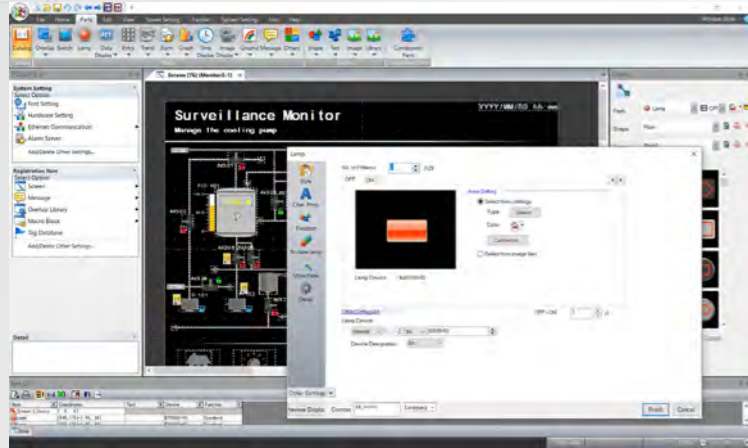

Computer	PC/AT compatible computer for Windows
OS ^{*2} ^{*3}	Vista(32bit, 64bit)/7(32bit, 64bit)/8(32bit, 64bit)/ 8.1(32bit, 64bit)/10(32bit, 64bit)/11(64bit)
CPU	Pentium 4 2.0 GHz or above recommended
Memory	1 GB or above (2 GB or above recommended)
Hard Disk	When installed: 4.0 GB or above
Disk Drive	DVD-ROM drive
Display	Resolution 1024 x 768 (XGA) or above recommended
Display Colors	High color (16-bit) or above
Others	Microsoft .NET Framework 4.0 or 4.5 (If a PC does not have .NET Framework 4.0 or 4.5, Framework 4.0 will automatically be installed on the PC.)

^{*1} The V10 series is compatible with Ver.6.2.0.0 and later.
^{*2} Administrator privileges are required for installation.
^{*3} V-SFT Ver. 6.1.6.0 or later is not supported on Windows XP/XP64 Edition.

Reduction of screen data transfer time

Modification and improvement of the transfer process has reduced the transfer time of screen data. The significant reduction of time for repetitive transfer during design debugging etc. contributes to the reduction of design and maintenance man-hours.

System Configuration

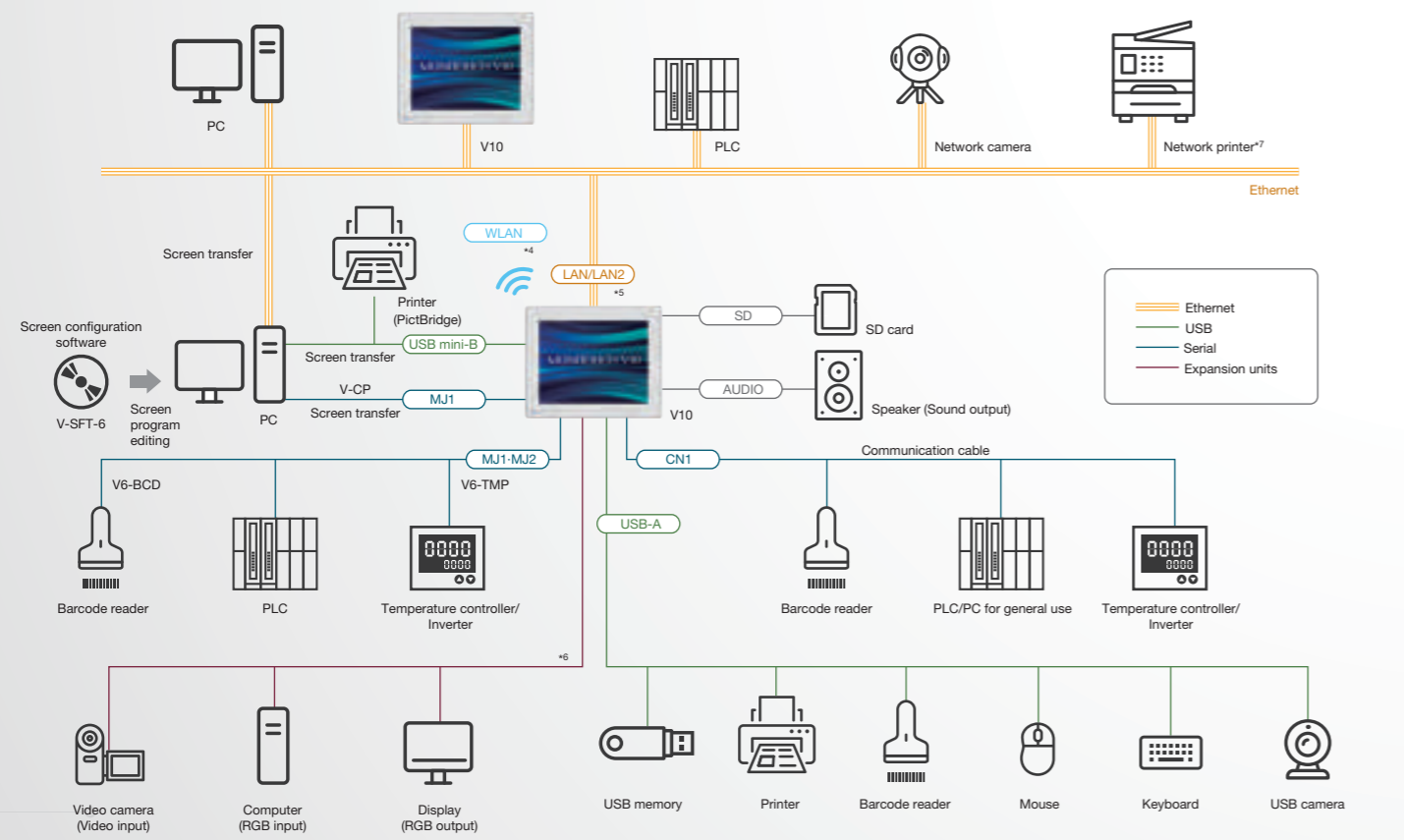

^{*4} Wireless LAN compatible products only.
^{*5} LAN2 is available only in products with extended wired LAN.
^{*6} Compatible with expansion units under development (Scheduled for release in April 2024).
^{*7} Compatible with EPSON ESC/P-R, HP HPLIP, OKI COREFIDO only. Wireless LAN connection is possible for wireless LAN compatible products.



SOFT MONITOUCH TELLUS-HMI iPad MONITOUCH functionality on iPad.

An application that can realize the MONITOUCH functionality on your iPad.
 TELLUS-HMI on iPad^{*1} allows you to take the operation panel with you.



Easy to take with you, regardless of installation location

It can be used for previously impossible tasks, such as operating multiple devices from a single tablet or operating equipment while checking its operation up close.



Repurpose MONITOUCH screen assets

MONITOUCH screen data files (extension .V10)^{*2} can be read and used directly on an iPad, reducing the effort required to create screens.

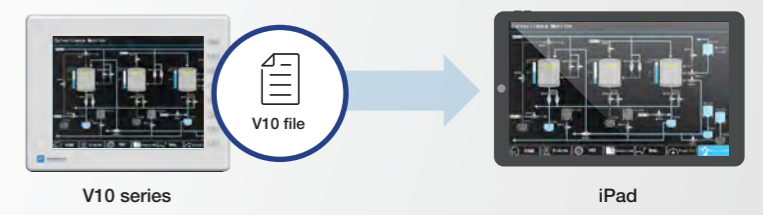

^{*2} Screen data support for the V10 series is under development. Scheduled for release in May 2024.

Compatible models

Model	System version
iPad	iPadOS 14 or later

Resolution

iPad resolution varies depending on the model. Screen data is created in XGA (1024x768) and automatically enlarged (fixed aspect ratio) for display on the iPad.

Free for 30 days^{*3} after first install
 After the free period ends, license authentication using a password is required.

Download from App Store
 Please scan with your iPad.

^{*3} Up to 100 start-ups.

Product Details

Model	Specifications				External Interface				Standard					Delivery Standard: ✓ Made to order: △				
	Display Size	Resolution	Touch Screen	Case Color	Power Supply	Video/RGB ^{*1}	AUDIO Output	Wireless LAN	Extended Wired LAN	UL61010	UL121201 ^{*2}	CE/UKCA	KC		Radio Act	Classification Standard ^{*3}		
V1015iS	15.0"	1024 x 768	Analog resistance film	Light gray	AC	✓	✓	—	—	—	—	—	✓	—	—	✓		
V1015iSD					✓	✓	—	—	✓	✓	✓	✓	—	✓	✓			
V1015iSLD					✓	✓	—	✓	✓	✓	✓	✓	—	✓	△			
V1015iSRD					✓	✓	✓	—	✓	✓	✓	✓	✓	—	△			
V1015iSB				Black ^{*4}	AC	✓	✓	—	—	—	—	—	—	—	—	—	—	△
V1015iSBD					✓	✓	—	—	✓	✓	✓	✓	—	✓	△			
V1015iSLBD					✓	✓	—	✓	✓	✓	✓	✓	—	✓	△			
V1015iSRBD					✓	✓	✓	—	✓	✓	✓	✓	✓	—	△			
V1012iS					12.1"	800 x 600	Analog resistance film	Light gray	AC	✓	✓	—	—	—	—	—	✓	—
V1012iSD	✓	✓	—	—					✓	✓	✓	✓	—	✓	✓			
V1012iSLD	✓	✓	—	✓					✓	✓	✓	✓	—	✓	△			
V1012iSRD	✓	✓	✓	—					✓	✓	✓	✓	✓	—	△			
V1012iSB	Black ^{*4}	AC	✓	✓				—	—	—	—	—	—	—	—	—	—	△
V1012iSBD		✓	✓	—				—	✓	✓	✓	✓	—	✓	△			
V1012iSLBD		✓	✓	—				✓	✓	✓	✓	✓	—	✓	△			
V1012iSRBD		✓	✓	✓				—	✓	✓	✓	✓	✓	—	△			
V1010iS		10.4"	800 x 600	Analog resistance film				Light gray	AC	✓	✓	—	—	—	—	—	✓	—
V1010iSD	✓				✓	—	—		✓	✓	✓	✓	—	✓	✓			
V1010iSLD	✓				✓	—	✓		✓	✓	✓	✓	—	✓	△			
V1010iSRD	✓				✓	✓	—		✓	✓	✓	✓	✓	—	△			
V1010iSB	Black ^{*4}				AC	✓	✓	—	—	—	—	—	—	—	—	—	—	△
V1010iSBD					✓	✓	—	—	✓	✓	✓	✓	—	✓	△			
V1010iSLBD					✓	✓	—	✓	✓	✓	✓	✓	—	✓	△			
V1010iSRBD					✓	✓	✓	—	✓	✓	✓	✓	✓	—	△			
V1008iSD					8.4"	800 x 600	Analog resistance film	Light gray	AC	✓	✓	—	—	✓	✓	✓	✓	—
V1008iSLD	✓	✓	—	✓					✓	✓	✓	✓	—	✓	△			
V1008iSRD	✓	✓	✓	—					✓	✓	✓	✓	✓	—	△			
V1008iSBD	✓	✓	—	—					✓	✓	✓	✓	—	✓	△			
V1008iSLBD	Black ^{*4}	✓	✓	—				✓	✓	✓	✓	✓	—	✓	△			
V1008iSRBD		✓	✓	✓				—	✓	✓	✓	✓	✓	—	△			

*1 Compatible with expansion units under development (Scheduled for release in April 2024) *2 Hardware Ver.b or later. For models incompatible with UL121201, please contact us. *3 Please contact us for more information. *4 The rear case is light gray.

Model



Optional Accessories List

Model	Product	V10 Standard			
		V1015iS	V1012iS	V1010iS	V1008iS
Configuration Software					
V-SFT-6	MONITOUCH screen configuration software Ver.6	✓	✓	✓	✓
Communication Units					
CUR-00	OPCN-1 (For V10/V9/TS2060i)	✓	✓	✓	✓
CUR-01	T-Link (For V10/V9/TS2060i)	✓	✓	✓	✓
CUR-02	CC-Link (For V10/V9/TS2060i)	✓	✓	✓	✓
CUR-03	Ethernet (For V10/V9/TS2060i)	✓	✓	✓	✓
CUR-04	PROFIBUS-DP (For V10/V9/TS2060i)	✓	✓	✓	✓
CUR-06	SX-bus (For V10/V9/TS2060i)	✓	✓	✓	✓
CUR-07	DeviceNet (For V10/V9/TS2060i)	✓	✓	✓	✓
CUR-08	FL-net (For V10/V9/TS2060i)	✓	✓	✓	✓
CUR-09	EtherCAT (For V10/V9)	✓	✓	✓	✓
Cables *1					
V-CP	Screen transfer cable (3m)	✓	✓	✓	✓
UA-FR	USB-A extension cable (1m)	✓	✓	✓	✓
V6-MLT	Multi-link 2 master cable (3m)	✓	✓	✓	✓
V6-TMP	Temperature controller cable (3m)	✓	✓	✓	✓
V6-TMP-5M	Temperature controller cable (5m)	✓	✓	✓	✓
V6-TMP-10M	Temperature controller cable (10m)	✓	✓	✓	✓
V6-BCD	Barcode reader cable (3m)	✓	✓	✓	✓
D9-FU-SPBCPU-2M	Fuji Electric SPH ^{*2} , SPB CPU (RJ45) RS-485 (4-wire connection)	✓	✓	✓	✓
D9-FU-SPBCPU-3M		✓	✓	✓	✓
D9-FU-SPBCPU-5M		✓	✓	✓	✓
D9-FU-SPFCPU-2M	Fuji Electric SPF CPU (Mini DIN4) RS-232C	✓	✓	✓	✓
D9-FU-SPFCPU-3M		✓	✓	✓	✓
D9-FU-SPFCPU-5M		✓	✓	✓	✓
D9-MB-CPUQ-2M	MITSUBISHI ELECTRIC A series / QnA series CPU (Dsub25) RS-422	✓	✓	✓	✓
D9-MB-CPUQ-3M		✓	✓	✓	✓
D9-MB-CPUQ-5M		✓	✓	✓	✓
D9-MB-CPUQ-10M		✓	✓	✓	✓
D9-MB-CPUQ-15M	MITSUBISHI ELECTRIC Q series CPU (Mini DIN6) RS-232C	✓	✓	✓	✓
D9-QCPU2-2M		✓	✓	✓	✓
D9-QCPU2-3M		✓	✓	✓	✓
D9-QCPU2-5M		✓	✓	✓	✓
D9-QCPU2-10M	MITSUBISHI ELECTRIC link unit (Dsub9) RS-232C	✓	✓	✓	✓
D9-QCPU2-15M		✓	✓	✓	✓
D9-MI2-09-2M		✓	✓	✓	✓
D9-MI2-09-3M		✓	✓	✓	✓
D9-MI2-09-5M	MITSUBISHI ELECTRIC FX series CPU (Mini DIN8) RS-422	✓	✓	✓	✓
D9-MI2-09-10M		✓	✓	✓	✓
D9-MI4-FX-2M		✓	✓	✓	✓
D9-MI4-FX-3M		✓	✓	✓	✓
D9-MI4-FX-5M	MITSUBISHI ELECTRIC FX series CPU (Mini DIN8) RS-422	✓	✓	✓	✓
D9-MI4-FX-10M		✓	✓	✓	✓
D9-MI4-FX-15M		✓	✓	✓	✓
D9-D25	Dsub9-Dsub25 conversion cable (0.3m)	✓	✓	✓	✓
Serial Expansion I/O Unit					
V-I/O	Serial expansion I/O unit for V10/V9	✓	✓	✓	✓
Communication Terminal Block					
TC-D9	Terminal converter for V10/V9/TS2000/V8	✓	✓	✓	✓
Battery					
V9-BT	Replacement battery for V10/V9	✓	✓	✓	✓
Protection Sheets*3					
V1015S-GS	Protection sheet for V1015iS	✓			
V1015S-GSN10	Protection sheet for V1015iS (Non-glare)	✓			
V1012S-GS	Protection sheet for V1012iS		✓		
V1012S-GSN10	Protection sheet for V1012iS (Non-glare)		✓		
V1010S-GS	Protection sheet for V1010iS			✓	
V1010S-GSN10	Protection sheet for V1010iS (Non-glare)			✓	
V1008S-GS	Protection sheet for V1008iS				✓
V1008S-GSN10	Protection sheet for V1008iS (Non-glare)				✓
SOFT MONITOUCH					
TELLUS-HMI iPad ^{*4}	TELLUS-HMI iPad license required (password authentication)				

*1 PLC connection cables other than those listed above are also available. Please contact us for more information.
*2 Cannot be used with some CPU hardware versions. D9-FU-SPHCPU-□□M is required separately. Please contact us for more information.
*3 5 sheets per set. *4 Screen data support for the V10 series is under development. Scheduled for release in May 2024.



TEL

+81-76-274-2144

E-mail

sales@hakko-elec.co.jp

WEB

www.monitouch.com

Various information regarding MONITOUCH.

- Questions
- FAQ page (useful for troubleshooting)
- Manual
- Upgrading configuration software, etc.

**Global Sales Network**

Our distributors are ready to support your worldwide business.

www.monitouch.com/site/distributors-e/distributors-oversea-01.html



The warranty of this product is as follows, unless there are special instructions that state otherwise in the quote, contract, catalog, or specifications at the time of the quote or order.

The purpose or area of use may be limited, and a routine checkup may be required depending on the product. Please contact the distributor from which you purchased the product, or Fuji Electric/Hakko Electronics for further information.

Please conduct inspection of the product promptly upon purchase or delivery. Also, please give sufficient consideration to management and maintenance of the product prior to accepting it.

1 Period and Coverage of the Warranty

1-1 Period

- (1) The period of the warranty is effective until twenty-four (24) months from the date of manufacture printed on the plate.
- (2) The above period may not be applicable if the particular environment, conditions or frequency of use affects the lifetime of the product.
- (3) The warranty for the parts repaired by our service department is effective for six (6) months from the date of repair.

1-2 Coverage

- (1) If malfunction occurs during the period of warranty due to negligence on the part of Fuji Electric/Hakko Electronics, the malfunctioning parts are exchanged or repaired free of charge at the point of purchase or delivery. However, the warranty does not apply to the following cases:
 - 1) The malfunction occurs due to inappropriate conditions, environment, handling or usage that is not specified in the catalog, instruction book or users' manual.
 - 2) The malfunction is caused by factors that do not originate in the purchased or delivered product.
 - 3) The malfunction is caused by another device or software design that does not originate in a Fuji Electric/Hakko Electronics product.
 - 4) The malfunction occurs due to an alteration or repair that was not performed by Fuji Electric/Hakko Electronics.
 - 5) The malfunction occurs because the expendable parts listed in the instruction book or catalog were not maintained or replaced in an appropriate manner.
 - 6) The malfunction occurs due to factors that were not foreseeable by the practical application of science and technology at the time of purchase or delivery.
 - 7) The malfunction occurs because the product is used for a purpose other than that for which it is intended.
 - 8) The malfunction occurs due to a disaster or natural disaster that Fuji Electric/Hakko Electronics are not responsible for.
- (2) The warranty is only applicable to the single purchased and delivered product.
- (3) The warranty is only valid for the conditions stated in (1) above. Any damage induced by the malfunction of the purchased or delivered product, including damage or loss to a device or machine and passive damage, is not covered by the warranty.

1-3 Malfunction Diagnosis

The initial diagnosis of malfunction is to be made by the purchaser. The diagnosis can be conducted by Fuji Electric/Hakko Electronics or our delegated service provider with due charge upon the request of the purchaser. The charge is to be paid by the purchaser at the rate stipulated in the rate schedule of Fuji Electric/Hakko Electronics.

2 Liability for Opportunity Loss

Regardless of the time of occurrence, Fuji Electric/Hakko Electronics are not liable for damage caused by factors that Fuji Electric/Hakko Electronics are not responsible for, opportunity loss on the part of the purchaser caused by the malfunction of a Fuji Electric/Hakko Electronics product, passive damage, damage due to a special situation regardless of whether it was foreseeable or not, or secondary damage, accident compensation, damage to products that were not manufactured by Fuji Electric/Hakko Electronics, or compensation towards other operations.

3 Period for Repair and Provision of Spare Parts after Production is Discontinued (Maintenance Period)

Discontinued models (products) can be repaired for seven (7) years from the date of discontinuation. Also, most spare parts used for repair are provided for seven (7) years from the date of discontinuation. However, some electric parts may not be available due to their short life cycle. In this case, it may be difficult to repair or provide the parts during the seven-year period. Please contact Fuji Electric/Hakko Electronics or our service providers for further information.

4 Delivery

Standard products that do not entail application setting or adjustment are regarded as received by the purchaser upon delivery. Fuji Electric/Hakko Electronics are not responsible for local adjustments and test runs.

5 Service

The price of the delivered or purchased products does not include the service fee for the technician. Please contact Fuji Electric/Hakko Electronics or our service providers for further information.

6 Scope of Application

The above contents shall be assumed to apply to transactions and product use in the country where a Fuji Electric/Hakko Electronics product is purchased. Please consult your local supplier or Fuji Electric/Hakko Electronics for details.

Safety Considerations

- For safe operation, read the instruction manual or user manual that comes with the product carefully or consult the distributor from which you purchased the product, before using the product.
- Products introduced in this catalog have not been designed or manufactured for such applications in a system or equipment that will affect human bodies or lives.
- Customers, who want to use the products introduced in this catalog for special systems or devices such as for atomic-energy control, aerospace use, medical use, passenger vehicle, and traffic control, are requested to consult the Hakko Overseas Sales Section.
- Customers are requested to prepare safety measures when they apply the products introduced in this catalog to such systems or facilities that will affect human lives or cause severe damage to property if the products become faulty.
- For safe operation, wiring should be conducted only by qualified engineers who have sufficient technical knowledge about electrical work or wiring.

Notes to consider before purchasing

- Appearance and specifications are subject to modification without prior notice due to technical improvements.
- Colors in the catalog may differ from the actual colors due to printing inaccuracies.
- Consult your distributor or us for further information about products in this catalog.

www.monitouch.com

Sales company :

Fuji Electric Co., Ltd.

URL : www.fujielectric.com/

Gate City Ohsaki, East Tower,
11-2, Osaki 1-chome, Shinagawa-ku,
Tokyo 141-0032, Japan

Phone : +81-3-5435-7066

Fax : +81-3-5435-7475

Manufacturer :

Hakko Electronics Co., Ltd.

URL : www.monitouch.com/

890-1 Kamikashiwano-machi,
Hakusan, Ishikawa 924-0035, Japan

Phone : +81-76-274-2144

Fax : +81-76-274-5136

E-mail : sales@hakko-elec.co.jp

Distributor

- * Product specifications and design are subject to modification.
- * Combined images are used for the screen images.
- * Product colors may differ from colors in brochure photos due to printing.
- * Windows and Excel are trademarks of Microsoft (USA) in the U.S. and other countries.
- * Other company and product names in this brochure are registered trademarks.